

L.I. Anatyuk^{1,2}, N.V. Pasechnikova³, V.O. Naumenko³, O.S. Zadorozhnyi³,
S.L. Danyliuk⁴, M.V. Havryliuk^{1,2}, V.A. Tiumentsev¹, R.R. Kobylanskyi^{1,2}

Thermoelectric Device for Contact Cooling of the Human Eye

¹*Institute of Thermoelectricity of the NAS and MES of Ukraine, Chernivtsi, Ukraine, anatyuk@gmail.com*

²*Yuriy Fedkovych Chernivtsi National University, Chernivtsi, Ukraine, romakobylanskyi@ukr.net*

³*State Institution "The Filatov Institute of Eye Diseases and Tissue Therapy of the NAMS of Ukraine", Odesa, Ukraine, pasnv2017@gmail.com*

⁴*Central Research Institute of the Armed Forces of Ukraine, Kyiv, Ukraine, gazkom1973@gmail.com*

The paper presents the results of the development of a thermoelectric device in the form of a monocular dressing for contact cooling of the human eye through the eyelids. The developed device allows controlled local contact cooling of the eye structures through the eyelids and is designed to treat the acute and chronic eye diseases, reduce intraocular pressure, and reduce pain and inflammatory processes of the eye. The design features of the device and its technical characteristics are presented.

Key words: thermoelectric device, thermoelectric cooling, hypothermia of the human eye.

Received 24.01.2020; accepted for publication 15.03.2020.

Introduction

Therapeutic hypothermia is a curative effect that involves reducing the patient's body temperature by forcing heat away from the surface of the body or internal organs to reduce the risk of ischemic tissue damage. Therapeutic hypothermia in medicine has been known for over 200 years as an effective and proven method of neuroprotection in patients with some critical conditions, which reduces the mortality of patients and reduces the amount of damage to brain tissue. Currently, therapeutic hypothermia is considered to be the most promising physical method of neuroprotective protection of the brain, since from the standpoint of evidence-based medicine there is no effective method of pharmacological neuroprotection in neuroresuscitation practice [1]. Therapeutic hypothermia is successfully used in various fields of medicine (cardiac surgery, neurosurgery, resuscitation, etc.) in order to increase the resistance of brain cells to ischemia [2-6].

It is known that cerebral metabolism changes with the temperature of the brain, on average by 6 – 8 % when the temperature of the body changes by 1°C [1]. Lowering the temperature of the neurons of the central

nervous system causes the development of metabolic depression in them, which leads to a decrease in oxygen consumption, increased resistance to hypoxia, ischemia and reperfusion [7, 8]. In general, the following mechanisms of the neuroprotective action of therapeutic hypothermia are currently distinguished: inhibition of destructive enzymatic reactions; inhibition of free radical reactions; plasticity protection of lipoproteins of cytoplasmic membranes; reduced oxygen consumption in areas of the brain with low blood flow; improving oxygen delivery to the ischemic zones of the brain and reducing intracranial pressure; inhibition of biosynthesis and production of excitotoxic neurotransmitters [9-12].

At the same time, it is known that general therapeutic hypothermia is accompanied by the risk of complications, so it can be applied only in specially equipped resuscitation units. In clinical conditions in an ophthalmic hospital, it is not justified due to the complexity of its implementation [3, 4]. In ophthalmology there is a prospect of using local therapeutic hypothermia, for example, to reduce intraocular pressure. According to some authors, this effect is achieved by reducing the production of intraocular fluid and improving the outflow of watery moisture.

In so doing, there is a decrease in pain syndrome [13-15]. There is evidence in the literature that local hypothermia of the eye can lead to a decrease in fibrin production, a decrease in bleeding volume, and a decrease in photodamage during surgery [16]. A number of authors demonstrate a decrease in choroidal blood flow and a decrease in damage to the hemato-retinal barrier in conditions of local hypothermia [17, 18]. There is evidence of the use of local hypothermia to reduce inflammatory reactions [19]. It is known that after local hypothermia significant hemodynamic changes occur in the eye that are characterized by a significant expansion of the vessels and a decrease in their peripheral resistance, leading to an increase in blood flow to the vascular tract, an increase in pulse volume and blood flow velocity [20].

There are various ways to cool the eyes. In the experiment, it was confirmed that with local contact hypothermia, a decrease in the temperature of the intraocular medium of the rabbit eye is possible, both by cooling directly the external surface of the cornea and when exposed to cold through closed eyelids [21]. To solve this problem, you can use, for example, a bubble with ice, laying it on the eyelids [14]. Another way to achieve local hypothermia is achieved by irrigating the outer surface of the eye with chilled solutions. During intraocular surgery, local hypothermia of the eye can be created by lowering the temperature of irrigation solutions [22]. With regard to modern technologies, the development of special thermoelectric devices for local contact eye cooling looks promising. This will allow more efficient and controlled use of the beneficial effects of therapeutic hypothermia for the treatment of ophthalmic diseases.

Therefore, *the purpose of this work* is to design and manufacture an experimental sample of thermoelectric device in the form of a monocular dressing for contact cooling of the human eye through the eyelids.

I. Device design and specifications

At the Institute of Thermoelectricity of the NAS and MES of Ukraine within cooperation agreement with the State Institution "The Filatov Institute of Eye Diseases and Tissue Therapy of the NAMS of Ukraine" a thermoelectric device was developed in the form of a monocular dressing for contact cooling of the human eye through the eyelids (Fig. 1). The technical characteristics of the device are given in Table 1.

The device is designed to treat acute and chronic eye diseases, reduce intraocular pressure, reduce pain and inflammation of the human eye. The developed thermoelectric medical device allows controlled local cooling of eye structures through the eyelids and makes it possible to develop and introduce the technology of controlled local therapeutic hypothermia in ophthalmology. This device is original and has no world analogues.

The device consists of two main functional units: cooling plate 1 and thermoelectric electronic cooling, control and power supply unit 2 (Fig. 2). The cooling plate 1 is a liquid heat exchanger made of a highly conductive material - copper. The electronic unit 2 comprises a thermoelectric cooling unit, a power supply unit and an electronic control unit based on a programmable thermoregulator of the type RE-202. In turn, the thermoelectric cooling unit contains a Peltier thermoelectric module [23, 24], liquid heat exchangers and a circulation pump.

The Peltier thermoelectric module is designed to cool or heat the liquid circulating in the outer circuit. The hot side of this thermoelectric module is cooled by an internal liquid circuit connected to the water supply network. The circulation pump provides for the circulation of the liquid coolant in the outer circuit.

The power supply unit is designed to power the thermoelectric module from an alternating current

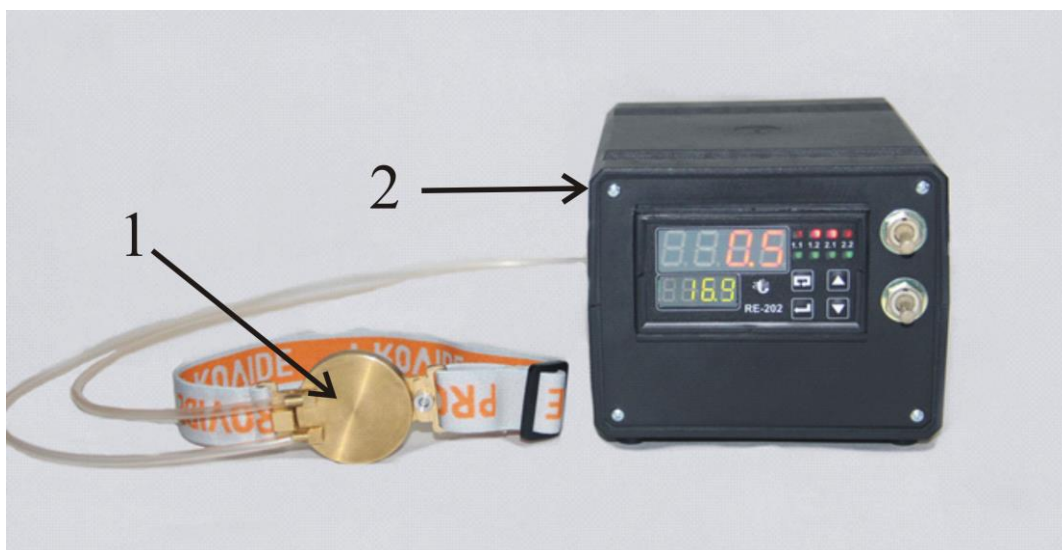

Fig. 1. Experimental sample of a thermoelectric device in the form of a monocular dressing for contact cooling of human eyes through the eyelids: 1 – cooling plate, 2 – thermoelectric electronic cooling, control and power supply unit.

Table 1

Device specifications

№	Device specifications	Parameter values
1.	Operating temperature range	(+5 ÷ +40) °C
2.	Temperature accuracy	± 0.2 °C
3.	Discreteness of the measured and set temperature	± 0.1 °C
4.	Temperature measurement error, not more	± 0.2 °C
5.	Thermal load in the external circuit, not more	20 W
6.	Total power consumption, not more	120 W
7.	Supply voltage (AC 50 Hz)	220 ± 10 V
8.	Overall dimensions of cooling plate	(75×45×12) mm
9.	Dimensions of thermoelectric electronic cooling, control and power supply unit	(180×120×100) mm
10.	Pump performance	40 l/h
11.	Length of hoses with external temperature sensor	1 m
12.	Device weight	1.5 kg
13.	Device run-up time	10 min
14.	Device continuous work time	48 h

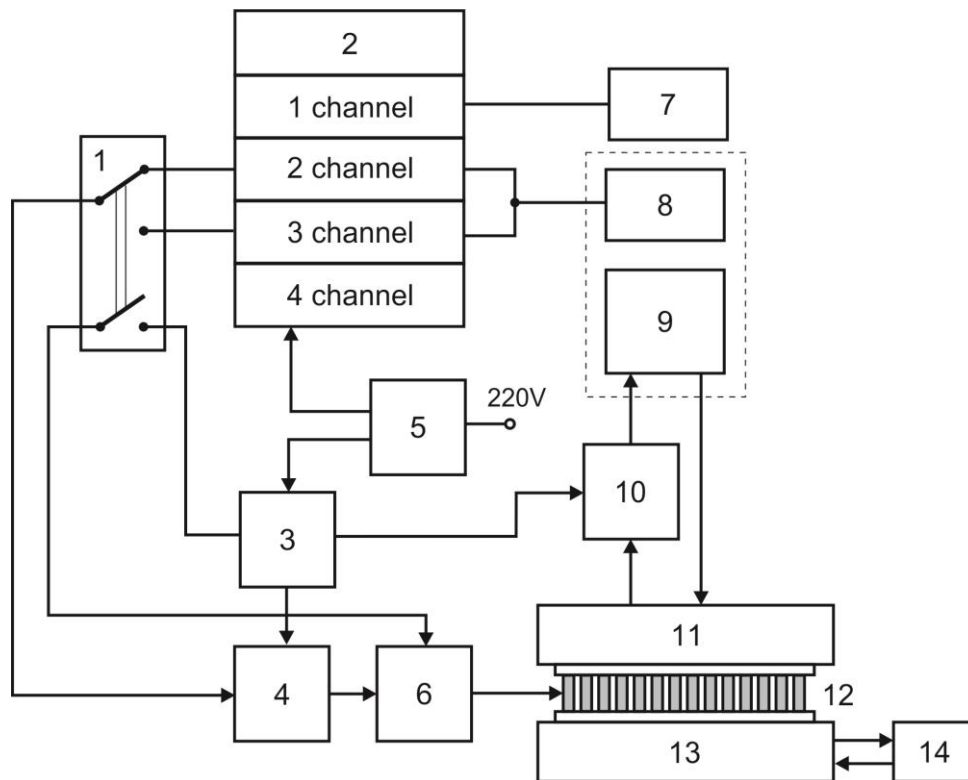

Fig. 2. Block-diagram of a thermoelectric device in the form of a monocular dressing for contact cooling of the human eye through the eyelids: 1 – “HEATING / COOLING” toggle switch, 2 – two-channel programmable temperature regulator RE-202, 3 – power supply unit, 4 – power key, 5 – “NETWORK” toggle switch, 6 – switch-board, 7 – object temperature sensor, 8 – temperature sensor of thermal stabilization circuit, 9 – heat exchanger of thermal stabilization circuit, 10 – circulation pump, 11 – water tank, 12 – thermoelectric Peltier module, 13 – cooling heat exchanger of thermoelectric Peltier module, 14 – water supply network.

network of 220 V. The temperature regulator RE-202 measures the temperature from internal and external thermoresistive sensors and generates control signals for the control circuit. In turn, the control circuit controls the thermoelectric module according to a predetermined program in order to maintain the operating temperature

set by the operator.

On the front panel of the device there are toggle switches "ON", "HEATING / COOL" and a digital display of the temperature regulator RE-202. The rear panel of the device accommodates a “NETWORK” toggle switch, a socket for connecting to a 220 V network,

sockets for connecting external temperature sensors “T1” and “T2”, “CIRCUIT INPUT”, “CIRCUIT OUTPUT”, “WATER INPUT”, “WATER OUTPUT ” unions and a 5 A fuse.

A block-diagram of the thermoelectric device for contact cooling of the human eye through the eyelids is shown in Fig.2, where 1 is “HEATING-COOLING” toggle switch, 2 is a two-channel programmable temperature regulator RE-202, 3 is a power supply unit, 4 is a power key, 5 is a “NETWORK” toggle switch, 6 is a switch-board, 7 is an object temperature sensor, 8 is a temperature sensor of thermal stabilization circuit, 9 is a heat exchanger of thermal stabilization circuit, 10 is a circulation pump, 11 is water tank, 12 is a thermoelectric Peltier module, 13 is a cooling heat exchanger of thermoelectric Peltier module; 14 is water supply network.

II. Operating principle of device

The operating principle of device is cooling or heating (thermal stabilization) of the human eye in order to treat acute and chronic diseases of the eye, reduce intraocular pressure, reduce pain and inflammatory processes.

The proposed device operates as follows (Fig. 2). The temperature sensor of object 7 is connected to the input of the 1st channel of temperature regulator 2 and the measured temperature is continuously displayed on the digital display of the temperature regulator RE-202. A temperature sensor for thermostabilization circuit 8 is connected to the inputs of the 2nd and 3rd channels of temperature regulator 2, and the outputs of the 2nd and 3rd channels come to the HEATING / COOLING toggle switch 1 and then to the power key 4. In this case, the second channel is programmed for cooling, the third channel for heating, and the fourth channel for measuring room temperature.

If the "NETWORK" toggle switch 5 is enabled, the mains voltage is supplied to the power supply unit 3 and the temperature regulator 2. If "COOLING" mode is selected with the toggle switch 1, then from the 2nd channel the PWM control signal is supplied to the power key 4, the switch-board 6 switches on the thermoelectric Peltier module 12 as a cooler and an electric current coming from the power supply unit 3 to the thermoelectric Peltier module 12 starts to lower its temperature, which leads to cooling of the liquid in the tank 11. The circulation pump 10 pumps the liquid through the heat exchanger 9 of the thermal stabilization circuit 9 and the object temperature is lowered until it is equal to the object temperature set by temperature regulator 2 controlled by the sensor 8. The heat released in the thermoelectric Peltier module 12 is removed by the heat exchanger 13 by means of water coming from the water supply network 14.

If “HEATING” mode is selected with the toggle switch 1, then from the 3rd channel the PWM control signal is supplied to the power key 4, the switch-board 6 switches on the thermoelectric Peltier module 12 as a

heater and the electric current coming from the power supply 3 to the thermoelectric Peltier module 12 starts to increase its temperature, which leads to heating of the liquid in the tank 11. The circulation pump 10 pumps the liquid through the heat exchanger 9 of the thermal stabilization circuit and the object temperature rises until it becomes equal to the object temperature set by temperature regulator 2, controlled by the sensor 8. The heat released in the thermoelectric Peltier module 12 is removed by the heat exchanger 13 with the help of water coming from the water supply network 14.

The specified device is simple, compact, portable and reliable in operation, which allows a doctor or a medical person to use it without special training, having read the instruction in advance. Thus, the technical advantages of this device include: the presence of a highly efficient thermoelectric Peltier module, the ability to measure and maintain a set temperature with a discreteness of ± 0.2 °C, the safety of use of the device and the ability to monitor the temperature of the human eye surface in real time.

III. Operating procedure

Preparation for work with the device comprises the following steps:

1. Place the device on a flat and stable surface. Connect an external T2 temperature sensor.
2. Connect water from the water supply network with hoses with the inner diameter of 6 mm to the “WATER INPUT” and “WATER OUTPUT” unions and turn on the low water flow.
3. Connect the external thermostatic circuit to the “CIRCUIT INPUT” union using hoses with an inner diameter of 4 mm. Pour liquid coolant, such as water, into the circuit. When filling the coolant, the thermostat must be above the cooling circuit. Turn on the thermostat with the “NETWORK” toggle switch and periodically turning on the “ON” toggle switch fill the completely cooling circuit with coolant. On filling the circuit, put the hose on the “CIRCUIT OUTLET” union. Turn off the toggle switch “ON”.
4. Set the circuit cooling temperature. To do this, on the temperature regulator RE-202 press on the «⇐» button three times, the green LED 2.1 will light up (Fig.1). The upper indicator will show the temperature of the sensor T1, the lower indicator will show the set temperature. Use the «▲» and «▼» buttons to set the required temperature, for instance, +10,0 °C.
5. Set the circuit heating temperature. To do this, on the temperature regulator RE-202 press on the «⇒» button two times, the green LED 1.2 will light up. The upper indicator will show the temperature of the sensor T1, the lower indicator will show the set temperature. Use the «▲» and «▼» buttons to set the required temperature, for instance, +35,0 °C.

On completion of all the above operations, the device is considered to be ready for use.

The procedure of working with thermoelectric device for contact cooling of the human eye through the eyelids

is as follows:

1. Turn on the power of the electronic unit 2 with the "NETWORK" toggle switch. The RE-202 temperature regulator indicators should light up. The upper indicator will show the temperature of sensor T2, the lower indicator – the temperature of sensor T1.

2. Select with the "HEATING/ COOLING" toggle switch the cooling or heating of coolant in the circuit.

3. Switch on the thermoelectric Peltier module with the "ON" toggle switch. In this case, the liquid will start circulating in the circuit and will be cooled or heated depending on the selected operating mode. The lower indicator will show the temperature of the liquid, and the upper indicator – the temperature of the object being measured. After some time, the temperature of the liquid will be equal to the set thermostating temperature.

4. If the device is to change the cooling or heating mode, switch off the "ON" toggle switch, move the "HEATING/COOLING" toggle switch and again switch on the "ON" toggle switch.

5. On completing the work, turn off the "ON", "NETWORK" toggle switches, turn off water in the cooling circuit, and unplug the device from the outlet.

ATTENTION! It is forbidden to turn on the device in the absence of water leaks from the water supply network through the "WATER INPUT", "WATER OUT" unions, because this can lead to failure of the thermoelectric Peltier.

The introduction of such a device into medical practice will be of great social and economic importance as it will reduce the risk of ophthalmic complications, preserve the viability of patients' eye structures, and provide highly skilled care both in specialized medical establishments and in extreme conditions. This, in turn, will provide the right conditions for the preservation of human health, improve the efficiency and quality of health care delivery and make a significant contribution to the development of the newest domestic medical thermoelectric equipment.

It should be noted that in order to confirm the effectiveness of the device, the development of methods of treatment and clinical trials, the developed experimental model of the device for contact cooling of the human eye through the eyelids was submitted to the

State Institution "The Filatov Institute of Eye Diseases and Tissue Therapy of the NAMS Ukraine" within cooperation agreement. The results of clinical trials of the device will be the subject of subsequent publications on this subject matter.

Conclusions

1. For the first time, a design was developed and an experimental sample was made of a thermoelectric device in the form of a monocular dressing for contact cooling of human eyes through the eyelids. The device is designed to treat the acute and chronic eye diseases, reduce intraocular pressure, and reduce pain and inflammation of the human eye. The proposed device has no world analogues.

2. The developed thermoelectric medical device makes it possible to carry out controlled contact cooling of human eye structures in the temperature range (+5 ÷ +40) °C and will further allow developing and introducing the technology of controlled local therapeutic hypothermia in ophthalmology.

Anatyshuk L.I. - Professor, Academician of the National Academy of Sciences of Ukraine, Doctor of Science (PhD), Director of the Institute of Thermoelectricity of NAS and MES of Ukraine;

Pasechnikova N.V. - professor, corresponding member of NAMS of Ukraine, MD, director of the State University;

Naumenko V.O. - Professor, Doctor of Science (MSc), Deputy Director for Scientific and Medical Work of the State University;

Zadorozhnyi O.S. - Candidate of Science (PhD), Researcher, Head of the Department of Laser Microsurgery of Eye DU;

Danyliuk S.L. - Doctor of Technical Sciences, Senior Researcher;

Havrylik M.V. - Researcher;

Tiumentsev V.A. - Senior Engineer;

Kobylanskyi R.R. Ph.D., Senior Researcher, Head of Medical Devices Division.

- [1] A.V. Tsarev, Emergency medicine 7, 186 (2014).
- [2] A.G. Alzaga, M. Cerdan, J. Varon, Resuscitation 70(3), 369 (2006) (<http://doi.org/10.1016/j.resuscitation.2006.01.017>).
- [3] K.H. Polderman, I. Herold, Crit. Care Med. 37, 1101 (2009) (<http://doi.org/10.1097/CCM.0b013e3181962ad5>).
- [4] H. Saad, M. Aladawy, Glob. Cardiol. Sci. Pract. 1, 44 (2013) (<http://doi.org/10.5339/gcsp.2013.7>).
- [5] M. Holzer, N. Engl. J. Med., 346, 549 (2002) (<http://doi.org/10.1056/NEJMoa012689>).
- [6] M.A. Yenari, H.S. Han, Nat. Rev. Neurosci 13, 267 (2012) (<http://doi.org/10.1038/nrn3174>).
- [7] S. Bernard, M. Buist, Critical Care Medicine 31, 2041 (2003) (<http://doi.org/10.1097/01.CCM.0000069731.18472.61>).
- [8] J.W. Lampe, L.B. Becker, Annu. Re. Med., 11, 104 (2011) (<http://doi.org/10.1146/annurev-med-052009-150512>).
- [9] L.V. Usenko, A.V. Tsarev, Obshchaya reanimatologiya – General Resuscitation 5(1), 21 (2009).
- [10] S.A. Mayer, V.A. Sessler, Therapeutic hypothermia (Marcel Dekker, New York, 2005).
- [11] M.E. Nunnally, R. Jaeschke, G.J. Bellingan, et al., Critical Care Medicine 39, 1113 (2011) (<http://doi.org/10.1097/CCM.0b013e318206bab2>).

- [12] P. Safar, Cerebral resuscitation from temporary complete global brain ischemia. In: Cerebral blood flow: mechanisms of ischemia, diagnosis, and therapy (Springer, Berlin, 2002).
- [13] G.F. Chanchikov, Z.P. Zavolskaia, V.I. Bereznikova, J. Ophthalmology 8, 594 (1978).
- [14] L.V. Shif, A.V. Taratynova, V.A. Neiman, N.V. Angelova, J. Ophthalmology 3, 187 (1981).
- [15] K. Tamai, A. Majima, F. Honda, Nippon Ganka Gakkai Zasshi 97, 509 (1993).
- [16] N.M. Jabbour, C.L. Schepens, S.M. Buzney, Ophthalmology 95, 1685 (1998).
- [17] H. Fujishima, Y. Yagi, I. Toda, J. Shimazaki, K. Tsuota, Am. J. Ophthalmol. 119, 301 (1995).
- [18] K. Tamai, E. Toumoto, A. Majima, Br J. Ophthalmol. 81, 789 (1997).
- [19] M.M. Zolotareva, K.I. Chvialeva, A.I. Vasilevich, Hypothermia with eye diseases (Minsk, 1978).
- [20] V.I. Lazarenko, G.F. Chanchikov, I.M. Kornilovskii, V.G. Gaidabura, J. Ophthalmology 6, 419 (1976).
- [21] O.S. Zadorozhnyi, R.E. Nazaretian, V.V. Mirnenko, V.A. Naumenko, N.V. Pasechnikova, Ophthalmology. Eastern Europe 1, 73 (2018).
- [22] L.I. Anatyshuk, N.V. Pasechnikova, V.A. Naumenko, R.E. Nazaretian, N.N. Umanets, R.R. Kobylanskyi, O.S. Zadorozhnyi, J. Ophthalmology 1, 33 (2019) (<http://doi.org/10.31288/oftalmolzh201913338>).
- [23] L.I. Anatyshuk, Thermoelements and thermoelectric devices. Handbook (Naukova Dumka, Kyiv, 1979).
- [24] L.I. Anatyshuk, Thermoelectricity. Vol. 2. Thermoelectric power converters (Institute of Thermoelectricity, Kyiv-Chernivtsi, 2003).

Л.І. Анатичук^{1,2}, Н.В. Пасєчнікова³, В.О. Науменко³, О.С. Задорожний³,
С.Л. Данилюк⁴, М.В. Гаврилюк^{1,2}, В.А. Тюменцев¹, Р.Р. Кобилянський^{1,2}

Термоелектричний прилад для контактної охолодження ока людини

¹Інститут термоелектрики НАН та МОН України, Чернівці, Україна, anatysh@gmail.com

²Чернівецький національний університет ім. Ю. Федьковича, Чернівці, Україна, romakobylanskyi@ukr.net

³ДУ «Інститут очних хвороб і тканинної терапії імені В.П. Філатова НАМН України», Одеса, Україна, pasnv2017@gmail.com

⁴Центральний науково-дослідний інститут Збройних сил України, Київ, Україна, gazkom1973@gmail.com

У роботі наведено результати розробки термоелектричного приладу у вигляді монокулярної пов'язки для контактної охолодження ока людини через повіки. Розроблений прилад дає можливість контрольованого локального контактної охолодження структур ока через повіки та призначений для лікування гострих і хронічних захворювань ока, зниження внутрішньоочного тиску, зменшення больового синдрому та запальних процесів ока. Наведено особливості конструкції приладу та його технічні характеристики.

Ключові слова: термоелектричний прилад, термоелектричне охолодження, гіпотермія ока людини.